

Intelligent microphone system

INSTRUCTION MANUAL

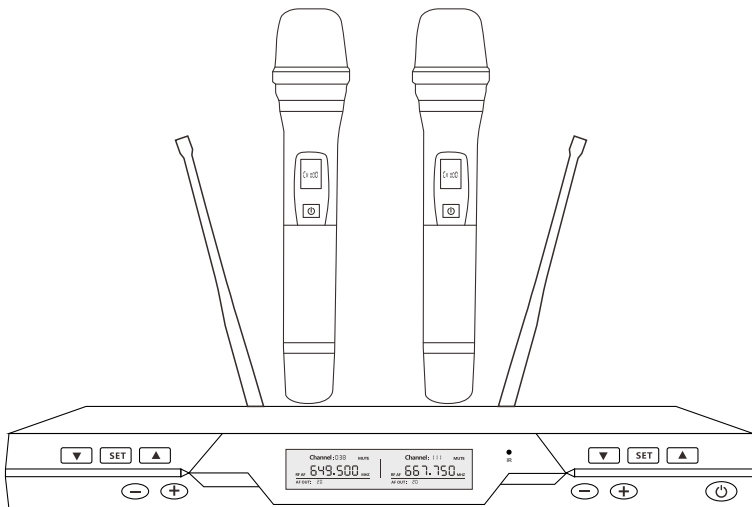

**AUTOMATIC INDUCTION
WIRELESS MICROPHONE**

OWNER'S MANUAL

CATALOG

Safe use regulations	1
Digital Pilot Series Induction Microphone System Features	2
The use and operation of intelligent induction receiver	3-5
The use and operation of intelligent induction microphone	6-7
Technical parameter	8
Operation method and precaution	9
Trouble and solution	10

Welcome and thank you for choosing to purchase our Smart Sensing Wireless Microphone System!

With many years of experience in the production of wireless sound transmission system equipment, the wireless microphone system produced by our company has been widely used in KTV boxes, stage karaoke OK, and various speech activities or concerts held in schools, theaters, stadiums and other places.

This product is easy to use and operate, and the quality is stable, which is favored by users. We have a professional technical team to help you solve technical problems.

Warning: Beware of electric shock or fire, the body must be protected from rain or placed in a humid environment.

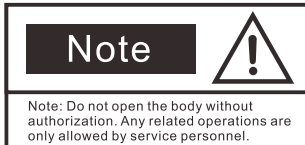

Symbol indicating that instructions and instructions must be followed strictly

- Read the operating instructions - Please read all relevant safety and operating instructions carefully before using the machine.
- Retain Operating Instructions - Please retain all relevant safety and operating instructions for this machine for future reference.
- Pay attention to warnings - Pay attention to all warnings during the application and operation of this unit.
- Follow Instructions - Follow all operating and usage instructions for this machine.
- Attachments - Only use attachments recommended by the manufacturer of the unit to avoid accidents.
- Rain and moisture - keep the unit away from water.
- Ventilation - Good ventilation is required for the use and storage of the machine, and the clearance around the device should be at least 5cm.
- Heat Sources - Keep away from heat sources, including: radiators, heaters, stoves, etc.
- No naked flame sources, such as lighted candles, should be placed on the equipment.
- When the battery is discarded, do not throw it away, please put it in the designated recycling bin.
- Do not place any liquid objects or heavy objects on the device to avoid water droplets or splashes.
- Equipment can be used in tropical or temperate zones.

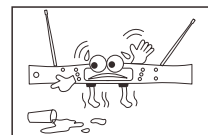
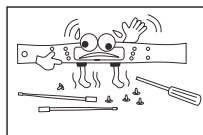
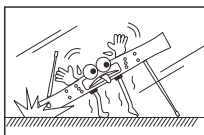
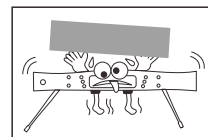
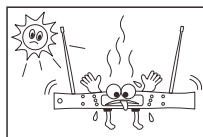
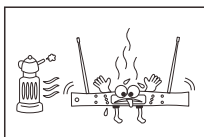

Do not use in the above environment! Non-professionals are not allowed to fold the system at will!

Digital Pilot Series Induction Microphone System Features

Automatic human hand sensing technology, the microphone leaves the hand and is still for 3-5 seconds and automatically mutes (any direction, any angle can be), it is an intelligent and automatic wireless microphone, it automatically shuts down and completely cuts off the power after 5 minutes.



Mute for 5 minutes and automatically turn off the transmitter



Enter the power saving state



Enter the power saving state



Automatic shutdown after 15 minutes of silence

- This product is equipped with digital pilot technology, which can effectively solve the phenomenon of mutual cross-frequency in KTV private rooms.
- This product is equipped with digital pilot technology, which can effectively solve the phenomenon of mutual cross-frequency in KTV private rooms.
- Equipped with a howling suppression circuit, debugging is simpler.
- Automatically search for non-interference channel function, installation is more convenient.
- The maximum output volume can be freely limited, and the adaptation range is wider.
- UHF band, phase-locked loop (PLL) frequency synthesis.
- 100×2 channels, channel spacing 240KHz/250KHz.
- Super heterodyne secondary frequency conversion design, with extremely high receiving sensitivity.
- The RF part adopts multi-stage high-performance dielectric filter, which has excellent anti-interference ability.
- The first intermediate frequency adopts a sound surface filter, and the second intermediate frequency adopts a three-stage ceramic filter, which improves the anti-interference ability of the product.
- The specially designed mute circuit greatly eliminates the impact noise when the microphone is turned on and off.
- The microphone uses the AA battery of Tesco, which can last for 6-10 hours.
- Microphone adopts a boost design, and the decrease of battery power does not affect the overall performance of the hand microphone.
- The ideal operating radius is up to 80 meters, which is suitable for various occasions.
- The default configuration is LCD screen, aluminum alloy microphone body.
- With adjustable transmit power and adjustable squelch threshold, the receiver can adjust squelch control through software, and the effective operating radius can be flexibly set between 10 meters and 80 meters according to needs.
- With infrared automatic frequency matching function, the microphone can be quickly synchronized to the working channel of the receiver.
- KTV engineering special model, two microphones, one host.
(The simulator can be configured with more than 100 KTV private rooms);
(The chip machine can be configured with about 40 KTV private rooms).

Applicable occasions: high-end KTV rooms, small and medium-sized performances, classrooms, conference rooms, etc.

Packaging type: conventional color box packaging
(see product sample for details).

The use and operation of intelligent induction receiver

This series of products consists of a handheld microphone and a receiver, as well as audio output cables, batteries, auxiliary mounting brackets and supporting screws, product instruction manuals and other accessories.

Intelligent induction receiver function description

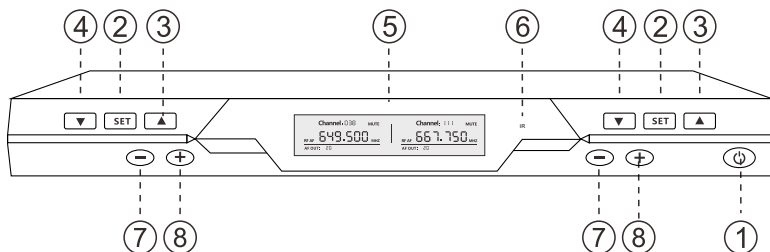

The use and operation of intelligent induction receiver

- ① Power switch button: lightly press the power switch, the LCD is on, the power is on; press the power switch for 3 seconds, the LCD is off, and the power is off.
- ② Select the Confirm button/Link button.
- ③ ④ Frequency adjustment button: Change the currently selected frequency.
- ⑤ Liquid Crystal Display (LCD): Displays channel, mute, received signal level, audio level, etc.
- ⑥ Infrared pairing window: cooperate with the "SET" key to transmit the channel parameters to the transmitter.
- ⑦ ⑧ Volume adjustment button.

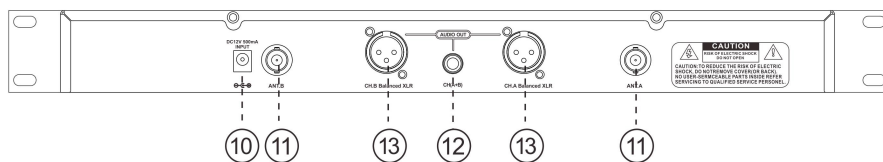

- ⑩ Power socket: DC12V 500mA power input socket, the center electrode of the socket is connected to a positive voltage.
- ⑪ Antenna jack.
- ⑫ Audio Mix Output: Mix the two signals together and output.
- ⑬ Audio balanced output: It is suitable for long-distance connection to effectively reduce the noise caused by the connecting line.

Receiver LCD Display Description

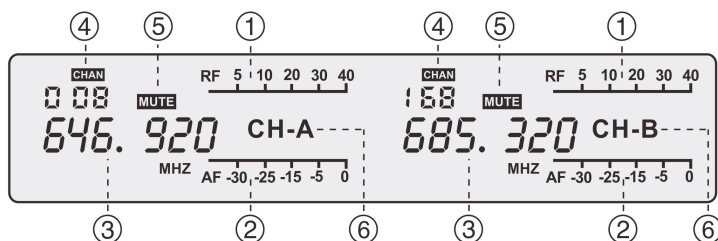

- ① 5-level RF level display: Displays the received RF signal strength.
- ② 5-level AF sound level display: Displays the strength of the audio signal.
- ③ Frequency menu display: 6-digit characters display the current operating frequency.
- ④ Channel menu display: Display the current working channel.
- ⑤ Mute display: When MUTE is on, it means that no RF signal is received or the handheld is in mute state.
- ⑥ Channel display: CH-A/CH-B respectively represent the current channel.

The use and operation of intelligent induction receiver

1. Host locking and unlocking

Turn off the host, press and hold the "④" key (frequency minus key) on the left side of the host, and press the power button to turn it on at the same time, the host can realize the addition and subtraction lock. If it is locked, the "∞" symbol on the main unit will be displayed, and if it is unlocked, the "∞" symbol on the main unit will not be displayed. Add and subtract locks and repeat this operation.

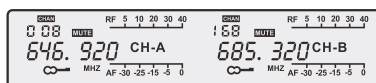

2. Automatic frequency matching

Turn on the power of the receiver and the handheld transmitter, press and hold the "②" key of the main unit to enter the infrared pairing mode, align the infrared frequency pairing window of the handheld transmitter with the IR transmitting window of the main unit, and press the "②" button of the main unit, the handheld transmitter will automatically sync to the frequency set by the host.

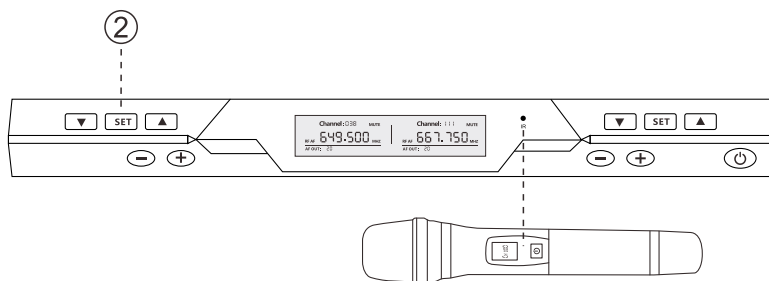

Note: Since this system uses its own encryption algorithm for each frequency point, the main unit can only be used with the hand microphone that has been successfully paired for the last time. If the frequency points displayed by the hand microphone and the main unit are the same, But the host has a signal but no sound, and you can re-operate the infrared frequency pairing operation.

The use and operation of intelligent induction microphone

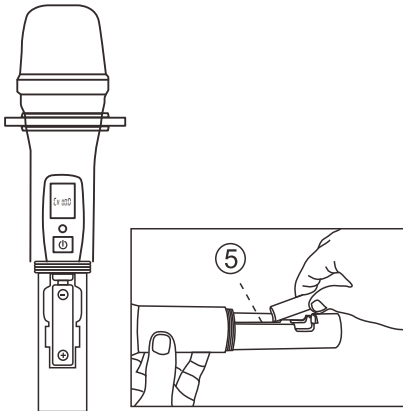
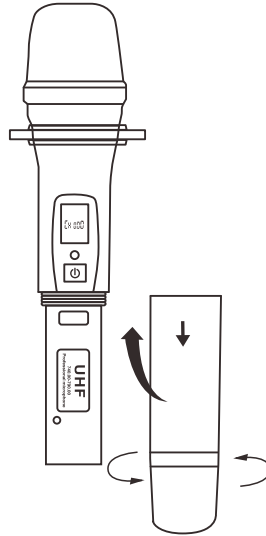
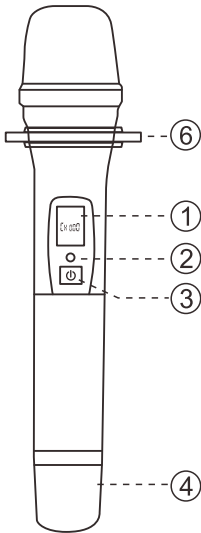

1. Description of the shape and structure of the microphone

- ① LCD screen
- ② Infrared pairing window
- ③ Power switch
- ④ Tailstock
- ⑤ Battery compartment
- ⑥ Anti-roll ring

The use and operation of intelligent induction microphone

1. Induction function on and off

Turn on the hand microphone, after the backlight goes out, press and hold the power button (note: keep pressing it), the hand microphone will shut down normally after 2 seconds (the power button is still held down at this time), wait for 10 seconds. The hand microphone will automatically turn on and display **sen on** (indicating that the induction function is turned on) or **sen off** (indicating that the induction function is turned off). At this time, release the power button and the hand microphone will enter the normal working mode. Switching the sensing function on and off is the same operation, just repeat the operation. It should be noted that the power button of the hand microphone is not released during the whole process.

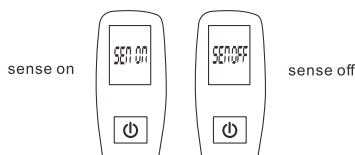

2. Infrared frequency pairing

Press SET on the main unit to enter the infrared pairing mode. The specific operation method is to open the hand microphone, align the infrared frequency pairing window of the hand microphone with the IR emission window of the host, and press the SET button of the host, and the hand microphone will automatically synchronize to the frequency point set by the host.

3. Power-on and power-off operations

Press the power switch down for about 2 seconds, the microphone display will light up and the LCD screen will display relevant working information, including the working frequency (channel), battery power and other information. Pay attention to check the battery power display status every time you turn it on, and choose whether to replace the battery according to the actual use time. Under normal circumstances, a pair of ordinary AA batteries can be used for 8 hours. When the battery power is 1 bar, the low voltage prompt "LOW BAT" will flash on the display, indicating that the battery power is about to run out, please replace the battery. In addition, the backlight of the display will automatically turn off a few seconds after the microphone is turned on to enter the energy-saving mode. If you need to check the information on the display during use, just press the power switch lightly, and press the power switch for about 3 seconds. The display shows "OFF", after which the microphone turns off. When the microphone is not used for a long time, please take out the battery, so as to avoid battery leakage and corrode the circuit board and damage the microphone.

4. Install the microphone battery

Remove the handheld microphone from the package, unscrew the tailpiece, insert 2 AA batteries according to the polarities indicated, then unscrew the tailpiece.

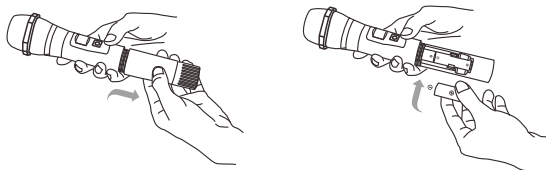

Technical parameter

Analog circuit machine technical parameter

Technical parameter:	645-693MHz/640-690MHz
Adjustable number of channels:	100×2
Oscillation mode:	phase-locked loop frequency synthesis (PLL)
Frequency Stability:	±10ppm
Receiving method:	superheterodyne secondary frequency conversion
Pilot mode:	digital pilot
Receive sensitivity:	-95~-60dBm
Audio frequency response:	40-18000Hz
Harmonic Distortion:	≤0.5%
Signal to noise ratio:	≥110dB
Audio output:	balanced output and mixed output
Transmit power:	3-30mW
Modulation method:	Frequency Modulation (FM)
Battery specification:	2 AA batteries
Power supply specification:	100-240V 50-60Hz 12VDC (switching power adapter) or 220VAC/50-60Hz 12VDC (linear power supply)
Power consumption:	≤10W

chip machine technical parameter

Technical parameter:	640-690MHz
Adjustable number of channels:	100×2
Frequency Stability:	±10ppm
Receiving method:	CPU control selection + pilot identification
Pilot mode:	digital pilot
Audio frequency response:	80-13000Hz
Harmonic Distortion:	≤0.5%
signal to noise ratio	-103dB
Audio output:	balanced output and mixed output
Transmit power:	3-30mW
Modulation method:	Frequency Modulation (FM)
Battery specification:	2 AA batteries
Power supply specification:	100-240V 50-60Hz 12VDC (switching power adapter) or 220VAC/50-60Hz 12VDC (linear power supply)
Power consumption:	≤10W

Operation method and precaution

How to operate

1. Connect the whole sound system;
2. Adjust the volume of the receiver and amplifier (karaoke amplifier) to the minimum position;
3. Turn on the power of the entire audio system in the sequence from the pre-stage to the post-stage;
4. Turn on the power of the transmitter;
5. Adjust the sound effect of the entire sound system: first adjust the receiver volume potentiometer to the midpoint position (for example, the receiver with a dark potentiometer has been adjusted to the middle position when leaving the factory), turn on the microphone switch, and face the Speak with the microphone to make the volume appropriate, and then carefully adjust the volume and volume control to make the voice clear and the volume appropriate. If necessary, you can hold the microphone to carry out the "walking" test in the entire field of use. Generally, it is appropriate that the microphone does not produce howling during the entire "walking" process;
6. If there is a problem with the wireless receiver system, please follow the troubleshooting in this manual to solve the problem. If it is not in the troubleshooting problem, please ask a professional to solve it or directly negotiate with the dealer;
7. After use, first turn off the power of the transmitter, and then turn off the power of the entire audio system in the order of the first stage to the previous stage.

Precautions

1. The installation position of the antenna directly affects the receiving effect of the receiver, so special attention should be paid to the correct installation method. The most important principle is to keep the distance between the microphone and the receiver as short as possible.
2. Avoid placing the receiver next to a computer or other equipment that generates RF (radio frequency) signals.
3. Avoid placing the receiver near computers or other devices that generate RF (radio frequency) signals.
4. The analog circuit can support 200 wireless microphones (80 chips) at the same time without interfering with each other, but it needs professionals to debug different channels.

Trouble and solution

Fault resolution

The following table lists some common faults and solutions; if you cannot solve the fault, please contact your dealer.

Problem Description	Solution
No sound (status: receiver RF display is off)	<ul style="list-style-type: none"> ● Check the transmitter whether is powered on. ● Check whether the positive and negative poles of the battery are out of order. ● Check the receiver's antenna connection. ● Make sure that there is no obstruction between the antenna and the transmitter.
No sound (status: receiver RF display is normal, AF display is normal)	<ul style="list-style-type: none"> ● Check that the volume of the receiver is at the minimum value. ● Check the receiver's volume and the connection between the amplifier is correct.
No sound (status: receiver RF display is normal, AF display is abnormal)	<ul style="list-style-type: none"> ● Swap the transmitter's pickup microphone.
Turn on the transmitter, the received signal has noise or interference from outside sound.	<ul style="list-style-type: none"> ● Check that the battery is securely installed. ● Eliminate nearby sources of RF interference. ● If using a guitar or other musical instrument, check the connections. ● Two transmitters may be using the same frequency, find and turn off one of them. ● The signal may be too weak, reposition the antenna as close as possible to the transmitter. ● Change to another channel.
After the transmitter is turned off, the receiver is noisy.	<ul style="list-style-type: none"> ● Eliminate sources of radio frequency noise. ● Reposition receiver or antenna.
The sound of the transmitter was occasionally lost during the movement of the venue.	<ul style="list-style-type: none"> ● Relocate the receiver and perform a "walk-through" test to observe the RF display. ● If you notice a loss of sound, mark the point and avoid walking there during the performance.
Unable to turn on transmitter	<ul style="list-style-type: none"> ● Replace transmitter battery.

OWNER'S MANUAL

***AUTOMATIC INDUCTION
WIRELESS MICROPHONE SYSTEM***